



302 Tenth Street
Troy, NY 12180
USA
Phone: 518.272.3565
Fax: 518.272.3585
www.qdrive.com

Data Sheet 2s102K Cryocooler

The 2s102K is a low vibration, no maintenance, highly reliable, acoustic Stirling (pulse tube) cryocooler for applications requiring cooling loads up to 8 watts at 77k. Each unit is driven by two of Qdrive's renowned STAR linear reciprocating motors with clearance seal pistons, providing wear free operation with no lubrication required. These compact systems are ideal not only for laboratory use but also for military and aerospace applications.

Qdrive's design is completely absent of cold moving parts or seals, eliminating maintenance that is required of most other technologies. The dual opposed motor/piston design within the pressure wave generator (PWG) is naturally balanced, reducing vibration and noise. When mass loading at the cooled point is of concern, Qdrive offers a remote head system (FAR), separating the PWG from the coldhead, which further reduces vibration. To improve power consumption and increase versatility, each cooler is designed to be adjusted "on-the-fly" to match varying cooling demands. These advantages are accompanied by competitive pricing in both small and large quantities, making them ideal not only for laboratory use but also for HTS, medical, liquefaction, and military and aerospace applications.

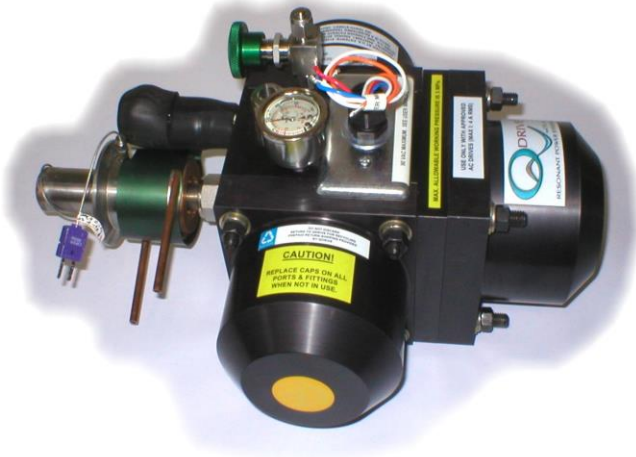

Figure 1: 2s102 Watercooled Cryocooler



Figure 2: 2s102 FAR Cryocooler

Operating Principle

The base cryocooler unit consists of a pressure wave generator driven by patented STAR linear reciprocating motors and an acoustic Stirling (pulse-tube) coldhead. The acoustic Stirling coldhead consists of a warm heat exchanger, a regenerator, a cold heat exchanger, a thermal buffer tube, a hot heat exchanger, an inertance tube, and compliance tank. Figure 3 below is shown as an inline configuration for clarity, but the actual coldhead is “folded over” at the cold heat exchanger to create a salient cold zone.

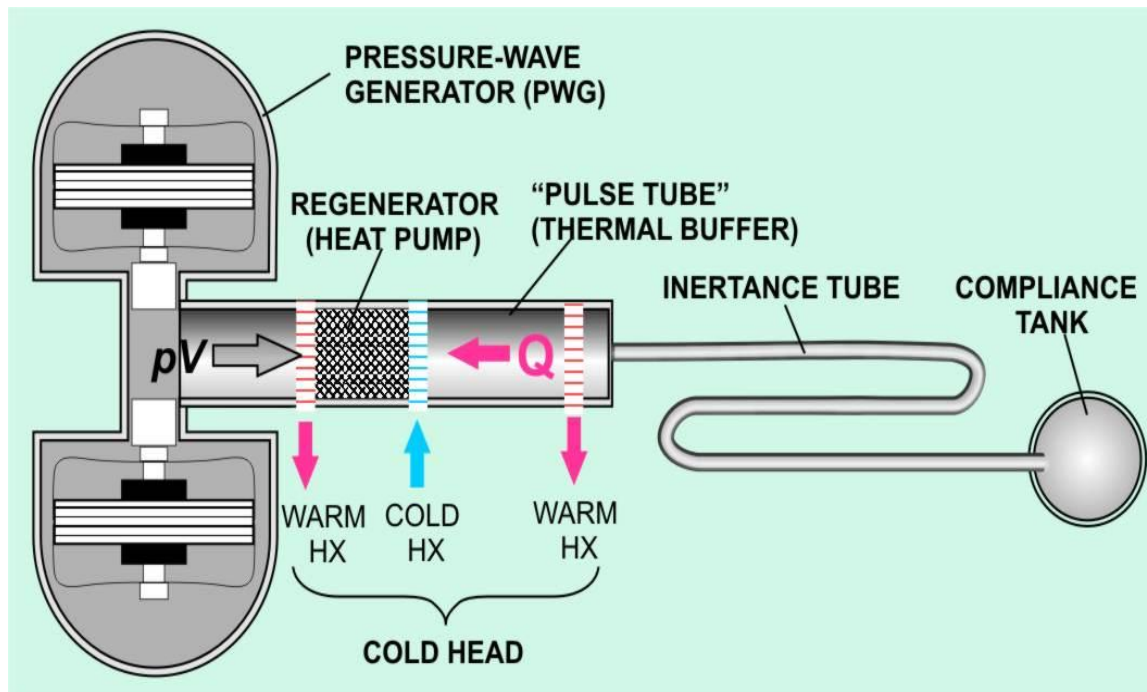

Figure 3: Thermoacoustic (pulse tube) Diagram

- 1) Pressurized helium gas is cyclically compressed and expanded relative to the mean pressure (charge pressure) by the pistons of the PWG.
- 2) With each forward stroke of the pistons, the gas moves through the aftercooler, or warm heat exchanger, where heat is removed. The gas parcel continues through the regenerator, which precools it before reaching the cold heat exchanger.
- 3) As the gas moves toward the cold heat exchanger, gas in the acoustic network (thermal buffer tube, hot heat exchanger, reservoir) also moves in the same direction. Even as the driven gas stops advancing, when the pistons reach their upper limits, the network's gas continues moving, driven by its own inertia in the high-speed inertance tube. This acts like a virtual piston, moving away from the cold exchanger, which expands the gas in that area. As it expands, it gathers heat from the surroundings (the area or substance to be cooled).
- 4) The pistons begin withdrawing and helium then moves back through the regenerator and aftercooler. Still delayed by its inertia, the gas in the network follows and the cycle begins again.
- 5) The cryocooler motors and heat exchangers are cooled by local air, water, or an optional closed water loop that consists of a reservoir, a pump, and a liquid-to-air heat exchanger.

Specifications

General:

Model 2S102K cryocooler generates 6-8 watts rated cooling output @ 77K, or 28 watts @ 150K, from 250 watts electrical input, rejecting to 20 C water, as shown in Figure 4. Exterior surfaces are mainly constructed of anodized aluminum or stainless steel, depending on the option selected. All forms have a coldfinger with NW50 O-ring sealed vacuum flange for mounting (optional CF/DN flanges available). Piston stroke is rated at 10mm, with a maximum rating of 12mm, and controller by the input power electronics. Instrumentation, electrical heat load, automatic temperature control, water-cooling, and drive electronics are optionally available. Acoustic coldheads have NO MOVING PARTS.

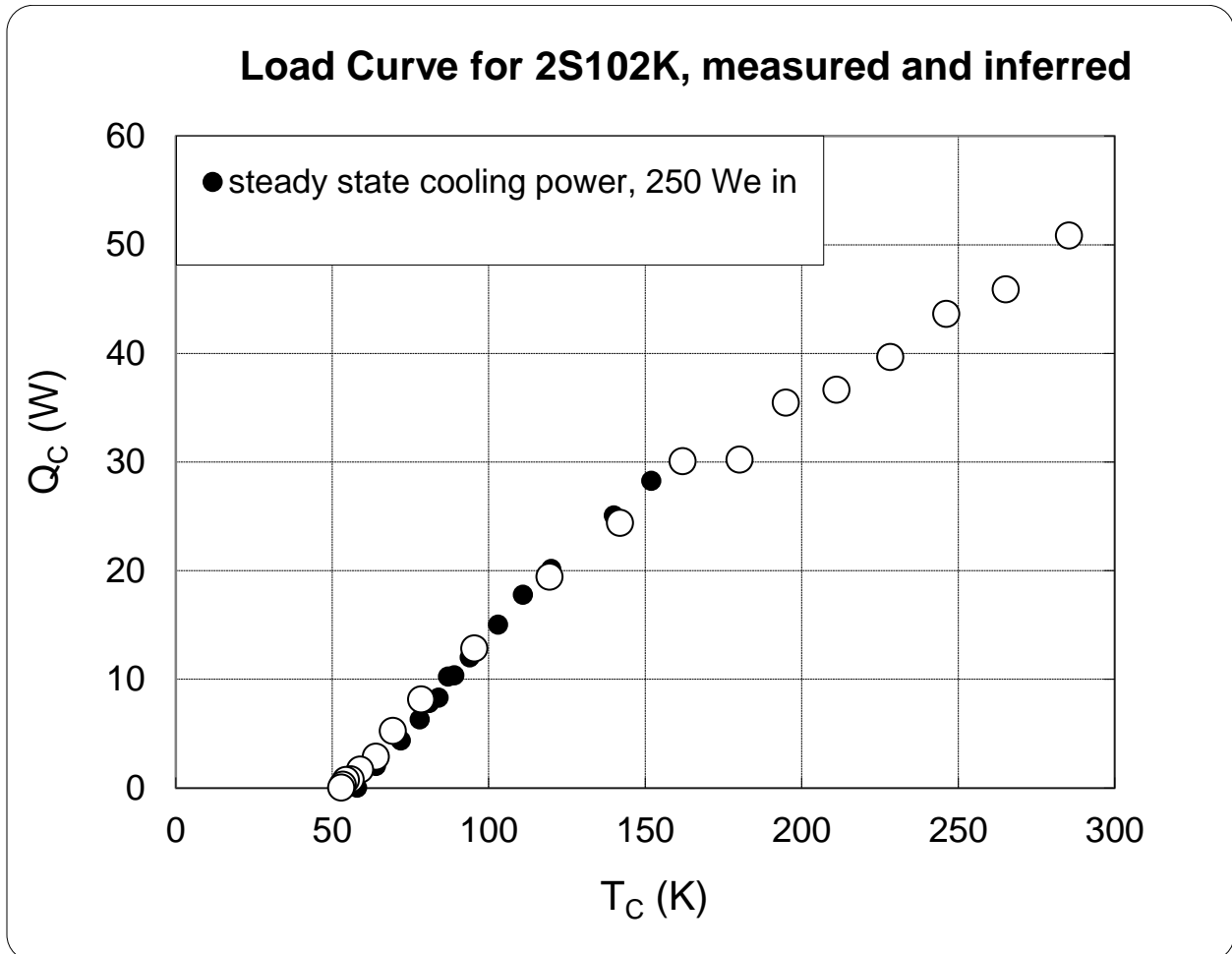

Figure 4: 2s102 Typical Load Curve

FOR BEST PERFORMANCE THE COLD FINGER SHOULD BE MOUNTED VERTICALLY AND FACING DOWN. QDRIVE'S SPECIFICATIONS ARE BASED ON THIS MOUNTING CONFIGURATION.

Materials of construction:

Anodized aluminum or 300 series stainless steel in most non electromagnetic parts except heat exchangers (copper). All vessel components are constructed in accordance with applicable ASME Vessel Code requirements, but are NOT stamped.

Mounting:

- Pressure Wave Generator: Four #10-32 tapped holes as outlined in Figure 7
- Coldhead: NW 50 vacuum flange
- Sample: Four #6-32 tapped holes, 0.50" on center

Connections (Gas & Water):

FAR flex line, 1 meter long with stainless steel braid and metallic bite seals.
Capped Schrader or Swagelok valve is provided for evacuation, filling, or connection. If water-cooled, (open-loop), standard water connections are 1/4 Swagelok tubes at the aftercooler.

Dimensions (approx):

See Diagrams below

Weight:

Approximately 15 kg water-cooled, net of options. Add 2 kg for air cooled units with shrouds. FAR head only with transfer line is < 3 kg. Overall shipping weight to be determined and depends on options selected.

Motor rating (subject to change):

- 125 x 2 We at 60 Hz, 10 mm stroke
- Core impedance @ 110VAC winding: 7 ohm DC, (45 @ 60 Hz)
- Stator inductance @ 110VAC winding: 110 mH
- Rated operating voltage/current: 110 VAC 1ø rms @ 60 Hz/1.25 A rms (0.8 power factor)
- Stroke limit 12 mm (10 mm operation must be centered within 1 mm)

Piston & Gas Management:

- Clearance seals, Rulon buffers
- Welded & bolted vessel for 3.0 MPa maximum allowable working pressure

Thermal Management:

- Water-cooled is standard with 1/4" Swagelok tubing external inlet/outlet ports
- 1 litre/minute minimum required flow at full load. Less than 10 kPa pressure drop (internal)
- Type E thermocouple on cold tip for monitoring (control included with -TI option only)

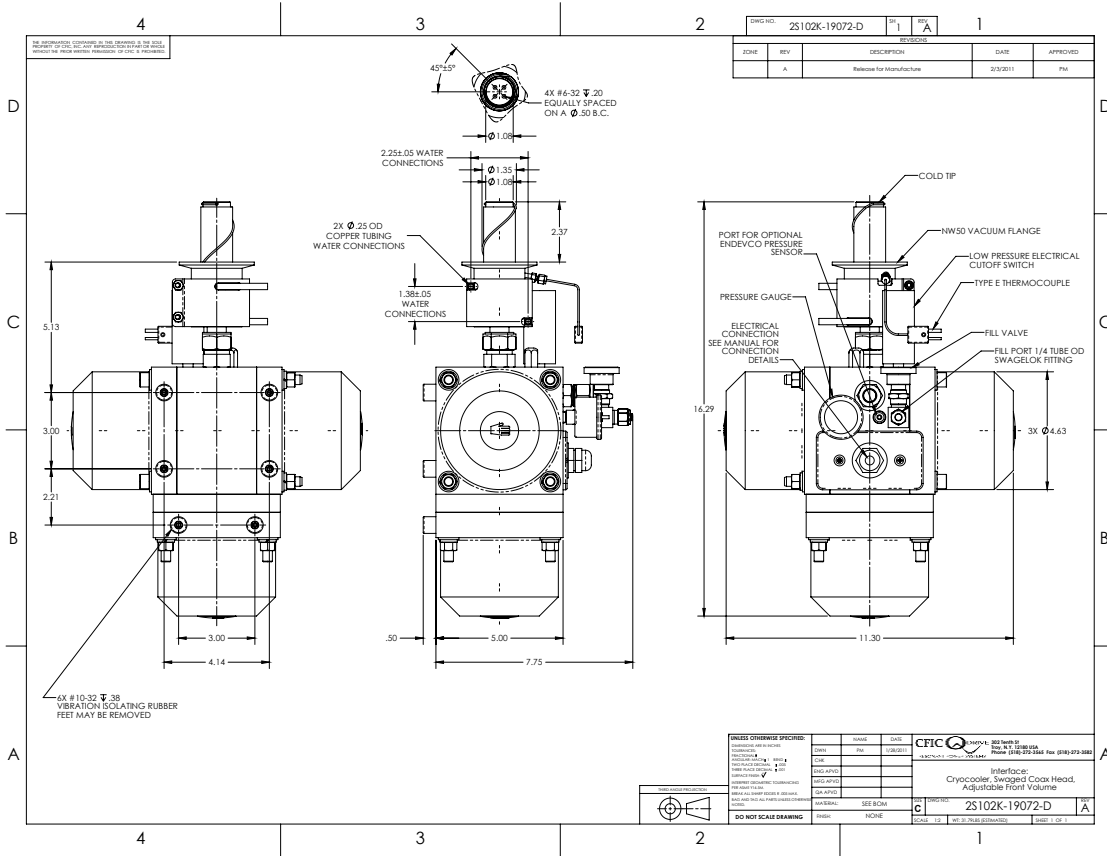

Figure 5: Typical 2s102 Water-cooled Cryocooler Dimensions

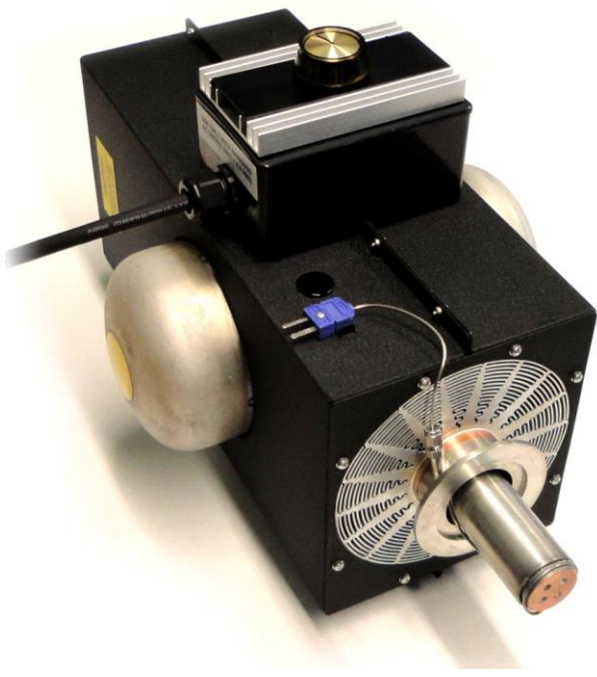
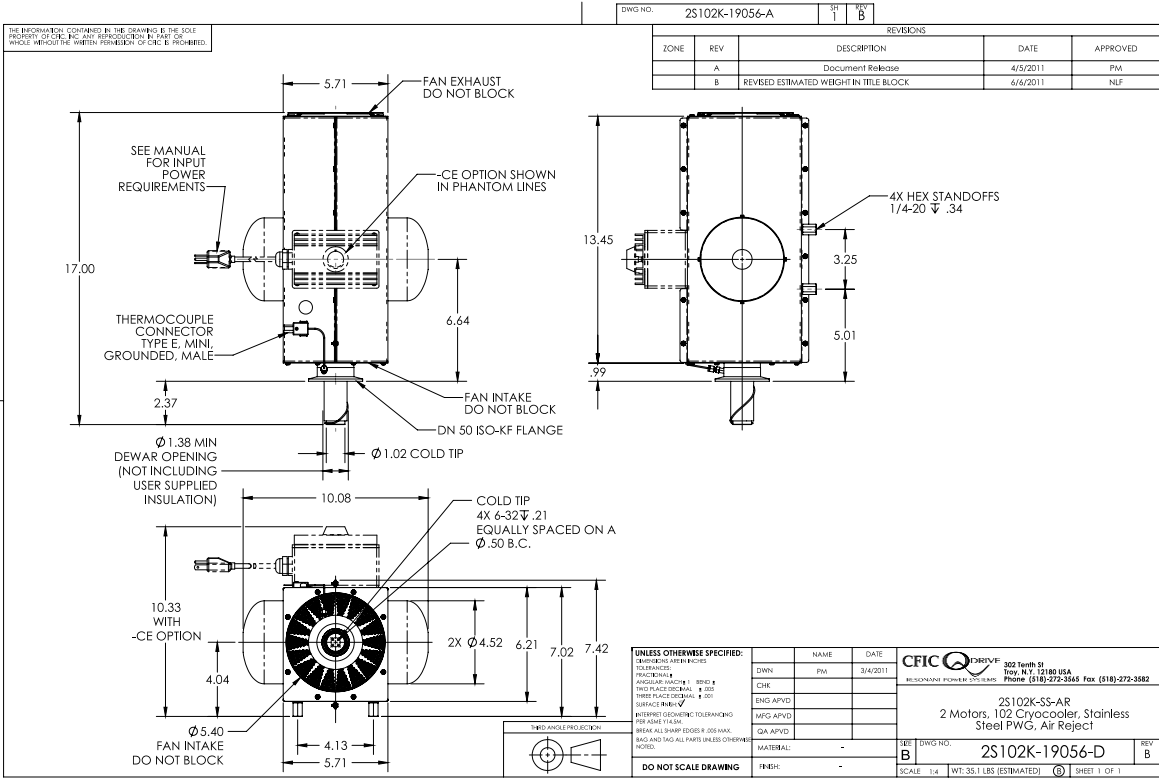

Figure 6: Typical 2s102 Air-cooled Cryocooler Dimensions

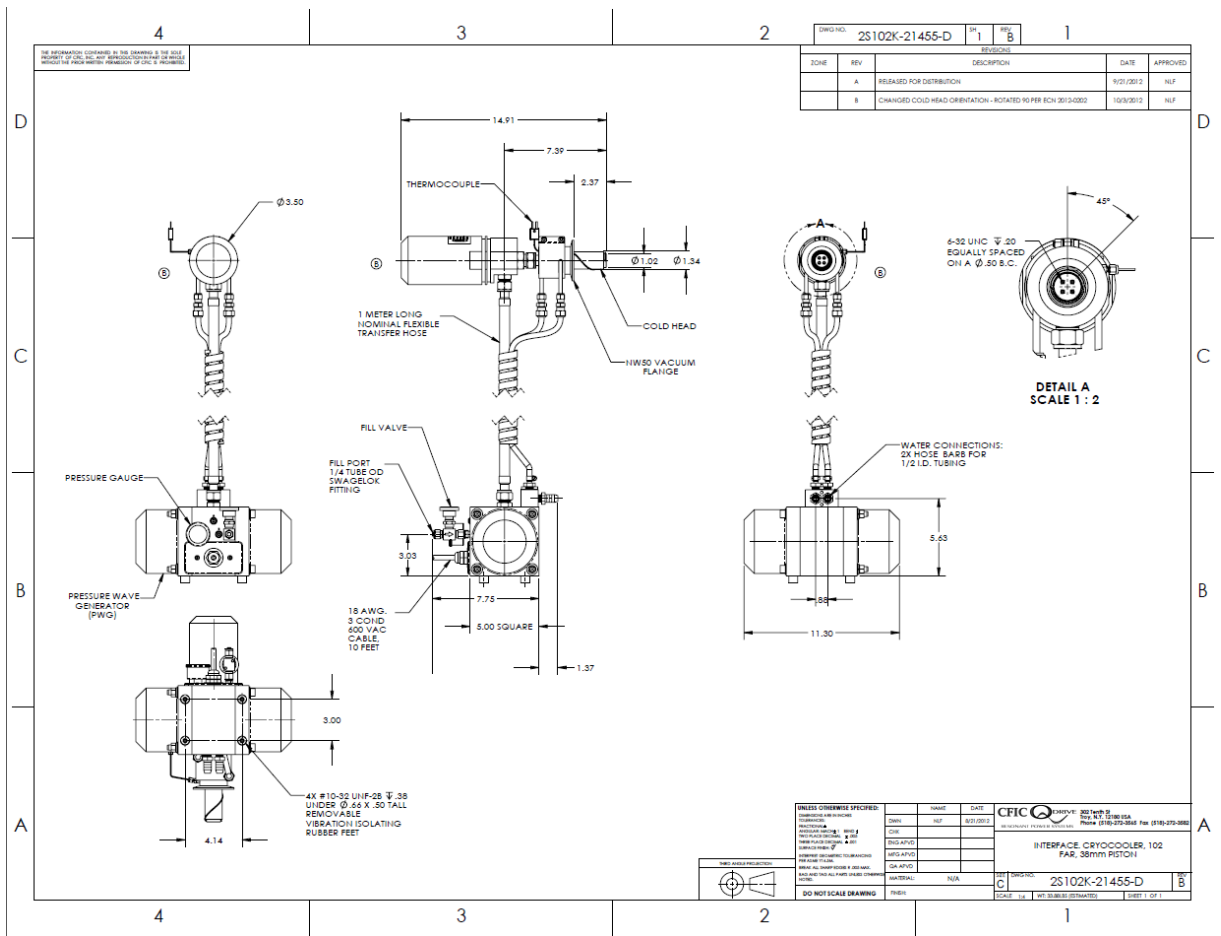

Figure 7: Typical 2s102 FAR Cryocooler Dimensions

Additional Options:

-SS: Stainless Steel Housing (AV-Aluminum vessel is standard)

- AV - tolerates higher operating and ambient temperatures, self-mounts on flat base
- SS - better gas retention for long-term, unattended operation

-AR: Air-Cooled. Not available with CL or AV option

- forced air including duct and fan, shown in Figure 6
- May reduce net cooling by 1-2 watts at all temperatures (vs 20C water cooled)

-CL: Closed-Loop Cooling. Additional CE option recommended

- 17.3" (439mm) W x 13.3" (338mm) H x 15.1" (384mm) D enclosure
- 1/16 hp centrifugal pump, 0.75 gal (2.8 L) reservoir, heat exchanger, circulating fan
- 35 lbs. (16kg)

-CE: Control Electronics Package

- SCR based microcontroller with manual controlled variable AC power supply
- specify 110-120VAC or 200-240VAC, 1 phase, 60Hz input, 8A capacity

-DE: Drive Electronics Package

- IGBT based inverter AC power supply (95% efficiency at full load)
- 200-240VAC, 1- or 3-phase, 50/60Hz input
- 9A continuous capacity, 25-100 Hz frequency range
- current limit (voltage foldover), thermal overload, short-circuit latching breaker
- air cooled EMF-shielded enclosure, NEMA 1/IP20 cabinet
- digital display & keypad for voltage, current, frequency and run time

-TI: Input-Modulating Temperature Control (DE option required)

- microprocessor controlled (Micromega CNi833), mounted to DE cabinet
- PID control of motors input voltage from cooler temperature
- +/-1 C control typical, Type E thermocouple (depends on user load)

-IP: Instrumentation Package

- dynamic pressure sensors: one at front for cycle wave and one at back, analogous to piston motion
- ENDEVCO piezo dynamic pressure tap at connection port (<2% error, <1 deg shift, +/-5V output)
- driver power supplies for transducers with BNC connector output (110Vac required)

-CF: Conflat Flange

- welded CF/DN 50 (3.38 inch) or CF/DN63 (4.50 inch) warm flange replacing NW50

-CW: Custom Windings

- non-standard voltage/current combinations or special insulation ratings on motor/alternator. Must specify # turns, coil connections, wire size and insulation grade

-LX: Liquefier/Subcooler Load

- single-pass, flow-through inert-fluid 2nd stream heat exchanger/condenser
- inlet, outlet and drain fittings to be determined by buyer. No storage dewar provided.
- vacuum insulated cold parts and process fluid connections

-RR: Refrigerated Rejection

- adds cryo capacity by lowering aftercooler coolant temperature below 20C
- 1.4/1.1kW @ 20C, 0.6/0.5kW @ 5C at 60/50 Hz input
- 435 wide x 570 deep x 305 high (mm), 35 kg, hose-connected
- 3 additional full-load amperes (208/230-60 Hz or 200V-50 Hz)
- 0.7-2.5 gpm (3-10 lpm) brass-body positive-displacement pump

All specifications and options are the most accurate representation of product at time of offering and subject to change without notice. Purchaser is responsible to verify details of interface requirements.